

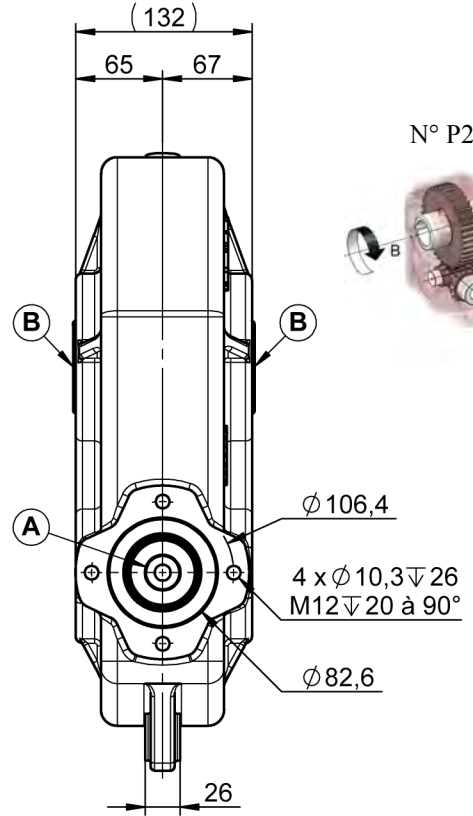

RH156 REDUCTEUR HYDRAULIQUE

RH156 HYDRAULIC REDUCER

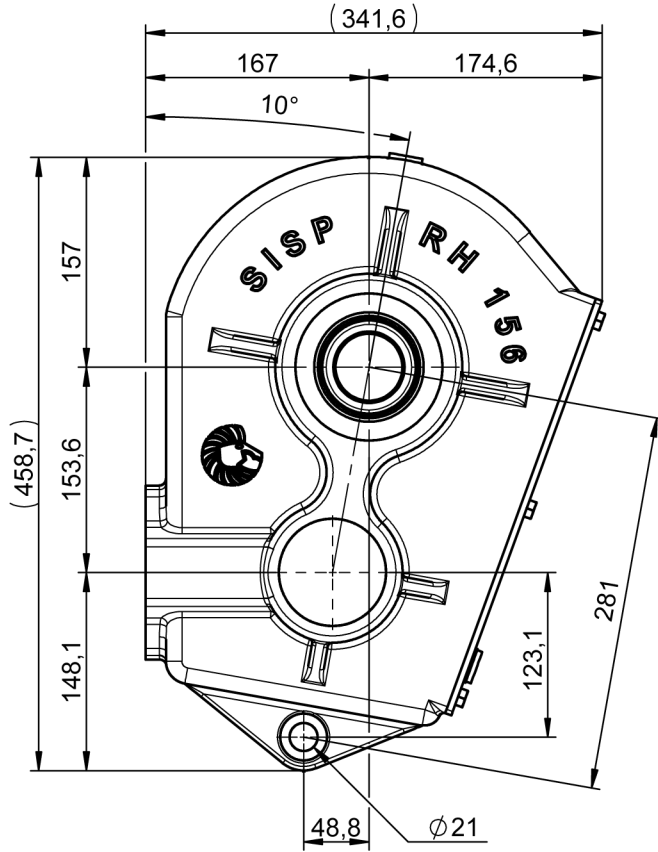

N° P21

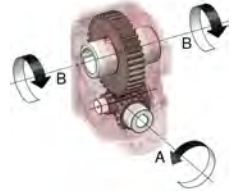

 2.1 L
TM80W90

 43 KG

REDUCTEUR / REDUCER								
RAPPORT RATIO	Ø	T/MN - RPM	A CV - HP	KW	NM	Ø	B T/MN - RPM	NM
1/21	Ø25 - Ø32	540	10.1	7.4	134	Ø35	25.7	2700
						Ø40		
						Ø45		
						Ø50		