

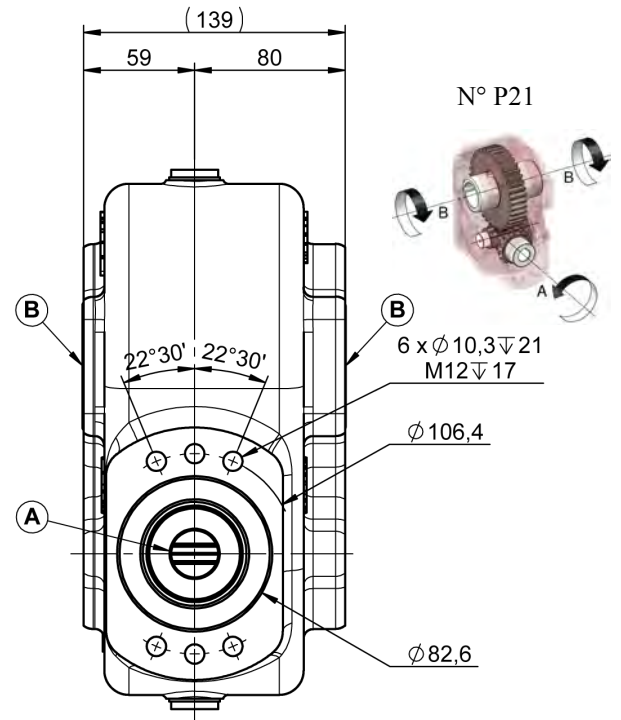

RH100 REDUCTEUR HYDRAULIQUE

RH100 HYDRAULIC REDUCER

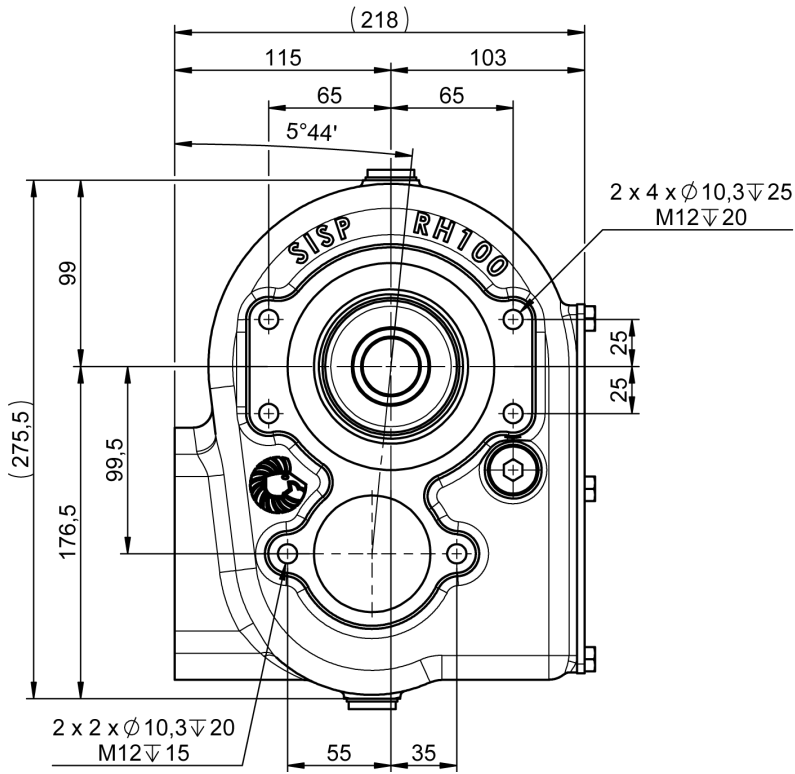

1.3 L
TM80W90

Livré sans huile / Delivered without oil

24 KG

REDUCTEUR / REDUCER								
RAPPORT RATIO	Ø	T/MN - RPM	A CV - HP	KW	NM	Ø	B T/MN - RPM	NM
1/4.88	Ø25 - Ø32	540	41	30	544	Ø30	111	2650
1/6.86			29	21	388	Ø35	79	2650
1/8.66	Ø25		22.9	17	304	Ø40	62	2650
1/10.64	Ø25		13	9.6	250	Ø45	51	1850